

## Kit # 5006A-( ) - Bypass Piston & Spring Replacement Kit For UV-5A, UV-5AT & UV-5ATC

This kit **MUST** be used when replacing the bypass piston in an older **S-series** (or earlier) **UV-5A** valve. Due to improvements in the current EECO bypass V-Guide piston, the spring must also be replaced when replacing the bypass v-guide piston. The replacement kit includes a new bypass v-guide piston with seal (1 & 4), spring buffer (2) and a new, shorter, bypass spring (3).

This kit can also be used in current UV-5AT & TC valves.

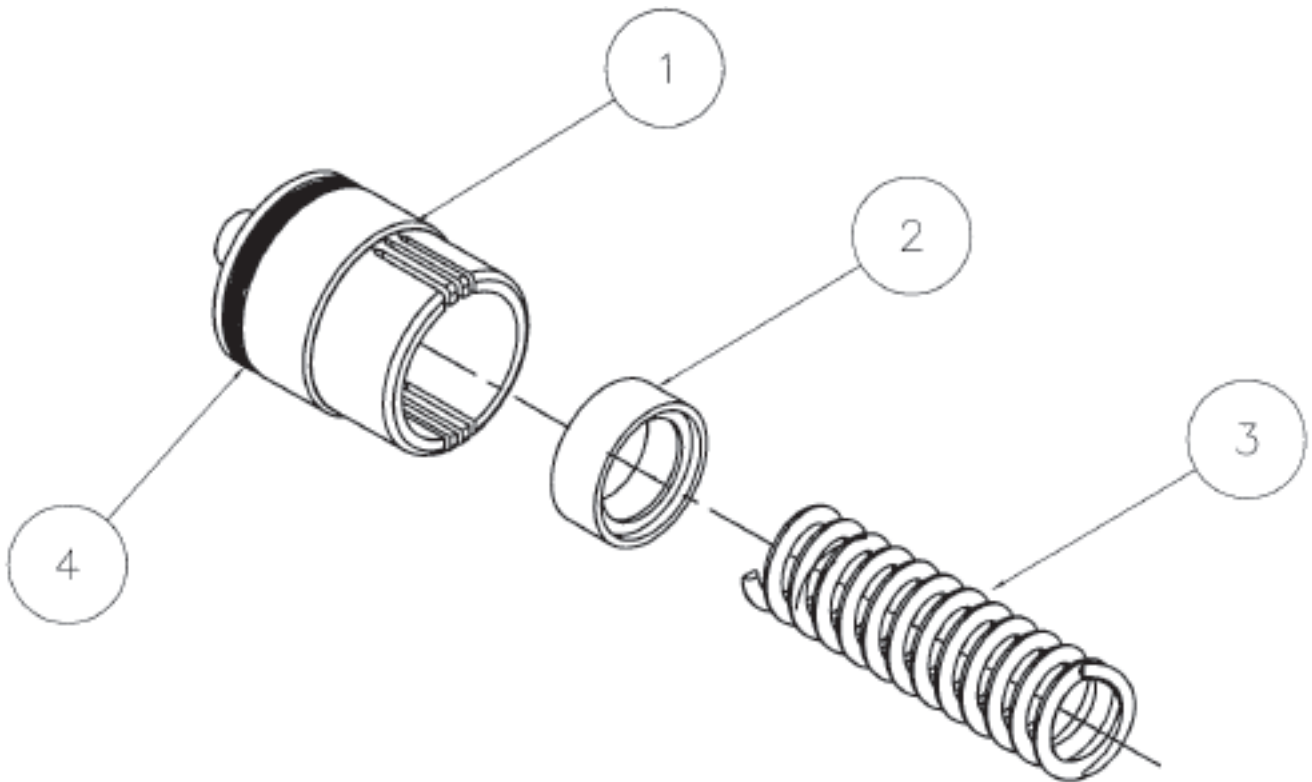

### Installation Procedures

1. Snap Spring (3) into Spring Buffer (2)
2. Insert Buffer/Spring assembly, buffer first, into Bypass Piston (1)
3. Insert Piston Assembly and Closure into Bypass Section of valve

### Kit Part Number & Sizes

PART NO.	PISTON SIZE
5006A-0	1/16*
5006A-1	1/8
5006A-2	1/4
5006A-3	1/2
5006A-4	3/4
5006A-5	1
5006A-6	1 1/4
5006A-7	1 1/2*

\* Old "S Series" (or earlier) Valves.

### Parts Included With Kit 5006A- ( )

ITEM	QTY.	PART NO.	DESCRIPTION
1	1	5006A-TAB	BYPASS V-GUIDE
2	1	5132A	SPRING CAP ASSEMBLY
3	1	5006-1	BYPASS SPRING
4	1	5900V	BYPASS V-GUIDE O-RING